

# Installation and Operations Manual

Model: H140



## Caution

This manual shows the suggested installation method. Any structural alterations necessary for installation must comply with all applicable building, health and safety code requirements.



## Caution

This unit is intended for general ventilation only. Do not use to exhaust hazardous or explosive material and vapors.

MP100520  
Revision 1.1

Airtech Equipment  
1095 Ohio Road  
Bourdreau-Ouest, New Brunswick  
Canada  
E4P 6N4

[www.airtech-107.com](http://www.airtech-107.com)

For Assistance call : 1-800-416-9111

# Table of Contents

- 1.0 Introduction ..... 2**
- 2.0 Specifications ..... 2**
  - 2.1 Air Flow (ERV Core) ..... 2
  - 2.2 Air Flow (HRV Core) ..... 2
  - 2.3 Product Data ..... 2
- 3.0 How It Works ..... 3**
- 4.0 Installation Scenarios ..... 3**
  - 4.1 Full Ducted System ..... 3
  - 4.2 Pre-existing Ductwork ..... 4
    - 4.2.1 New Exhaust and Recirculation ..... 4
    - 4.2.2 New Recirculation Only ..... 4
- 5.0 Pre-Installation Survey ..... 5**
  - 5.1 Locate the Unit ..... 5
  - 5.2 Plan the Ductwork ..... 5
- 6.0 Installation Instructions ..... 6**
  - 6.1 Installing Exterior Hoods & Vents ..... 6
  - 6.2 Installing Interior Ductwork & Vents ..... 7
    - 6.2.1 No Existing Euctwork ..... 7
    - 6.2.2 Pre-Existing ductwork ..... 8
      - 6.2.2.1 New Exhaust and Recirculation ..... 8
      - 6.2.2.2 New Recirculation only ..... 8
  - 6.3 Mounting the Unit ..... 9
  - 6.4 Connecting Ducts to the Unit ..... 9
- 7.0 Electrical Controls ..... 11**
- 8.0 How to Operate the Controls ..... 12**
  - 8.1 Primary Dehumidistat ..... 12
  - 8.2 20-Minute Timer ..... 12
- 9.0 Verifying the Installation ..... 13**
  - 9.1 Unit-mounted Controls ..... 13
  - 9.2 Primary Dehumidistat ..... 13
  - 9.3 Optional Controls ..... 13
- 10.0 Scheduled Maintenance ..... 13**
- 11.0 Certifications & References ..... 14**
- 12.0 Troubleshooting ..... 15**
  - 12.1 Airtech 107 ..... 15
  - 12.2 Home Ventilation ..... 16
- 13.0 Options ..... 17**
  - 13.1 20-Minute Timer ..... 17
  - 13.2 Fresh Outside Air Filter Upgrade ..... 17
  - 13.3 UV Germicidal Light ..... 17
  - 13.4 230 VAC option ..... 17
- 14.0 Electrical Diagram ..... 18**
- 15.0 Personal Information ..... 19**

## 1.0 Introduction

Congratulations on your purchase of an Airtech 107! The Airtech 107 is a complete all-season ventilation system for your **entire house**. Our revolutionary dual-core air exchange system replaces contaminated, humid air with clean, fresh air in every level of your home, in any climate, without unwanted condensation or the need to defrost. The result? No unsightly drains or annoying defrost schedules to hinder your enjoyment of a comfortable, contaminant-free living environment.

This Installation and Operation Manual will help you get acquainted with the functions and operation of your Airtech 107, as well as ensure an efficient and hassle-free installation of your new ventilation system.

## 2.0 Specifications

### 2.1 Air Flow (ERV Core)

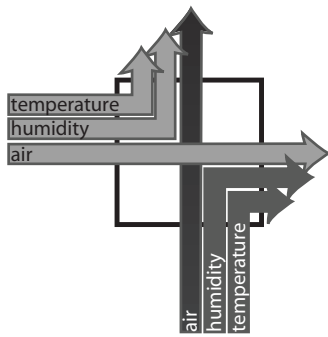

### 2.2 Air Flow (HRV Core)

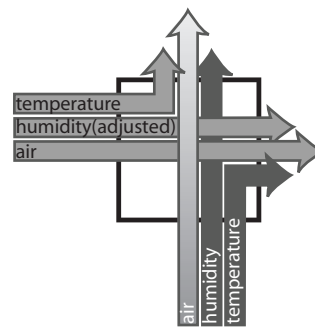

### 2.3 Product data

#### Top

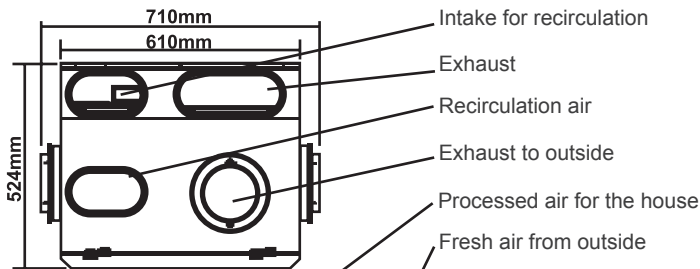

#### Front

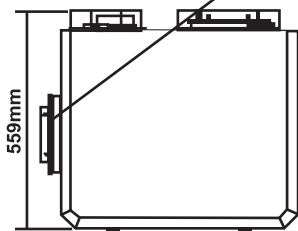

#### Side

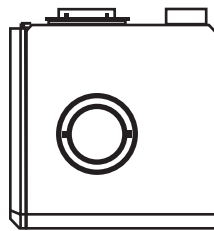

<b>Dimensions:</b>	28" x 22" x 21" including collars
<b>Weight:</b>	75 LBS including packaging
<b>Access</b>	Latched and hinged front access to filters and cores
<b>Duct Connection:</b>	- Three insulating double collars with 6" round connections to outside and main supply. - Fits standard 6" or 8" ducts - 6" oval collar for basement circulation.
<b>Mounting:</b>	Mounted from joist
<b>Electrical:</b>	120VAC@60HZ 0.8 amps, 96 watts max@120CFM 0.3 amps, 41 watts@60CFM
<b>Filters:</b>	Cleanable polyurethane foam air filters Optional electronic air cleaner
<b>Defrost:</b>	Processor controlled frost prevention system
<b>Warranty</b>	5 years on cores and 4 years on parts

## 3.0 How It Works

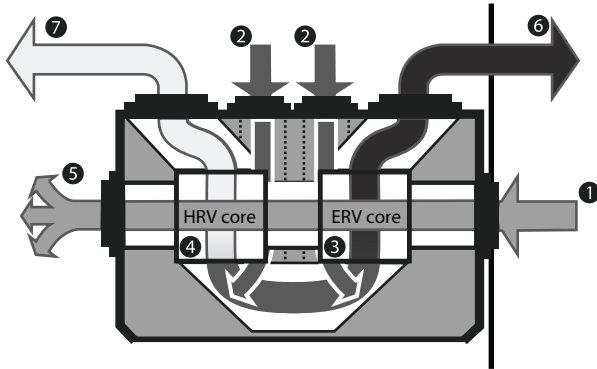

- 1 Fresh outdoor air enters the unit and flows through the ERV core.
- 2 Stale air and toxins from upper levels, basement, and crawl spaces enter the unit from two of the top ports.
- 3 In the summer, the ERV core transfers the excess humidity and temperature from the incoming air to the outgoing air. The preferred humidity and temperature level from the inside environment is then transferred to the incoming fresh air. The process is reversed in winter.
- 4 The second core, the HRV core, is dedicated completely to the basement. The newly adjusted humidity level of the fresh air is maintained, but the temperature levels are transferred.

- 5 The resulting fresh air – with temperature and humidity levels similar to the interior environment – is distributed throughout the house.
- 6 Stale air and toxins are expelled to the outside of the house.
- 7 The added benefit of the AirTech-107 – circulated air to the basement. This air helps control the basement's air quality and virtually eliminates humidity to create a completely livable space.

## 4.0 Installation Scenarios

### 4.1 Fully Ducted System

(For homes without any existing ductwork due to an existing forced-air system.)

This installation scenario will require a completely new duct system throughout the entire house.

Contaminated, humid air is exhausted from high humidity areas like the basement, bathrooms, kitchen, and laundry room. Fresh air taken from outside is passed through the ERV and HRV exchange elements where humidity and temperature are exchanged with the contaminated air leaving the building. The fresh air is then supplied to the basement, bedrooms, and other principal living areas to create a comfortable, contaminate-free living environment

A dedicated air recirculation system for the basement is a unique feature of the Airtech 107 and will transform the dampest, mustiest basement into a dry, comfortable living area or storage space. The recirculation system takes fresh, dry air from the upper levels of the house and recirculates it to the basement before exhausting it back to the outside.

Homes with two stories or more will require at least one exhaust vent at the highest level of the house.

In the basement it is recommended to have at least one exhaust vent close to the floor as the humidity in a basement tends to concentrate near the floor.

Please refer to chapter 6.2.1 for specific installation instructions.

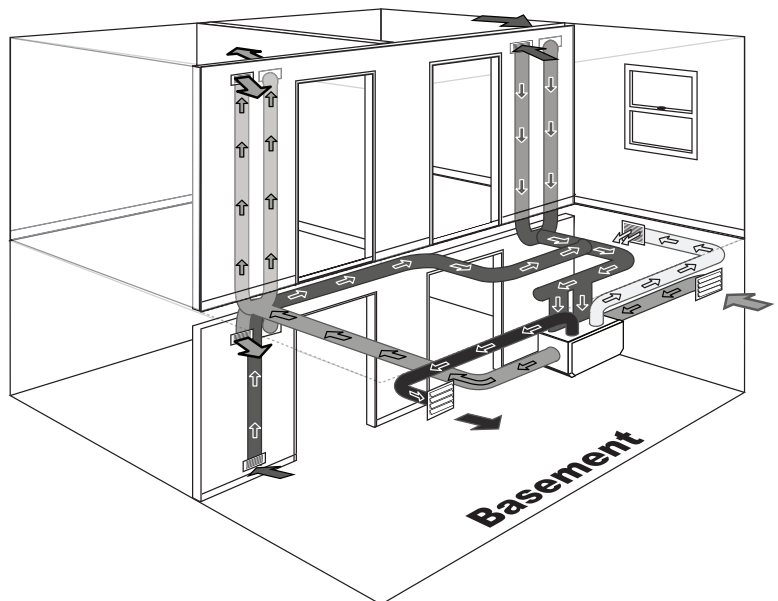

## 4 | Installation Scenarios

### 4.2 Pre-existing Ductwork

(For homes with existing ductwork due to an existing forced-air system.)

#### 4.2.1 New Exhaust & Recirculation

This installation scenario will require new ductwork for the exhaust and recirculation systems, and a tie-in to the existing ductwork of a forced-air system for the fresh air supply.

Contaminated, humid air is exhausted from high humidity areas like the basement, bathrooms, kitchen, and laundry room. Fresh air taken from the outside is passed through the ERV and HRV exchange elements where humidity and temperature are exchanged with the contaminated air leaving the building. The fresh air is then supplied to the return plenum of the air handler and distributed to the basement, bedrooms, and other principal living areas via the air handler's existing duct system.

A dedicated air recirculation system for the basement is a unique feature of the Airtech 107 and will transform the dampest, mustiest basement into a dry, comfortable living area or storage space. The recirculation system takes fresh, dry air from the upper levels of the house and recirculates it to the basement before exhausting it to the outside.

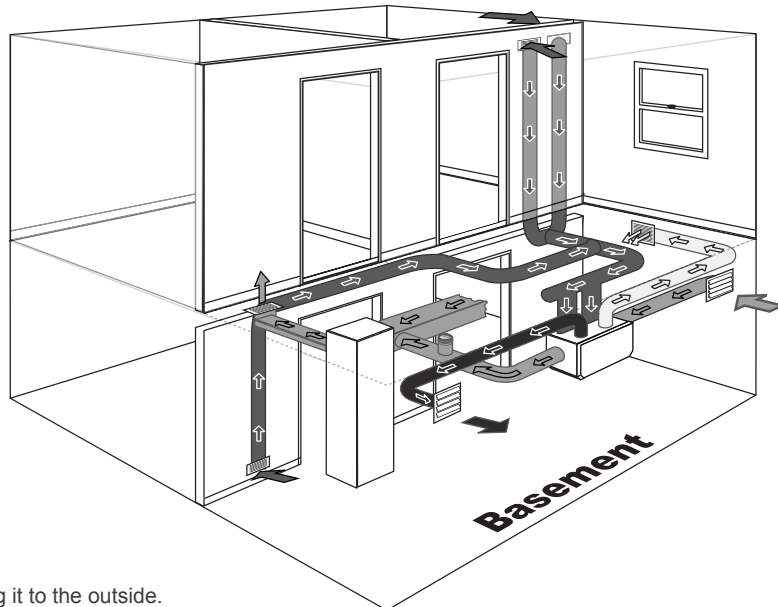

For this type of installation, it is not necessary for the forced-air blower to run while the unit is in operation. The Airtech 107 is powerful enough to circulate fresh air to all rooms of the house without blower assistance.

Homes with two stories or more will require at least one exhaust vent at the highest level of the house.

In the basement it is recommended to have at least one exhaust vent close to the floor as the humidity in a basement tends to concentrate near the floor.

#### 4.2.2 New Recirculation only

This installation scenario will require new ductwork for the recirculation system, and a tie-in to the existing ductwork of a forced-air system for both the stale air exhaust and fresh air supply.

Contaminated, humid air is exhausted from high humidity areas like the basement, bathrooms, kitchen, and laundry room via the air handler's existing duct system. The contaminated air is drawn through the air handler's return plenum and into the Airtech 107's ERV and HRV exchange elements. At the same time, fresh air taken from the outside is passed through the ERV and HRV exchange elements where humidity and temperature are exchanged with the contaminated air leaving the building. The fresh air is then supplied to the return plenum of the air handler and distributed to the basement, bedrooms, and other principal living areas via the air handler's existing duct system.

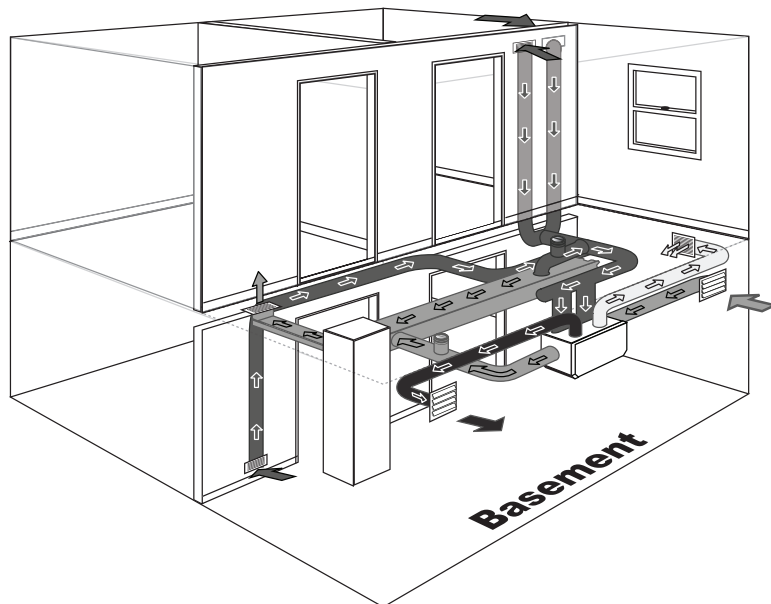

A dedicated air recirculation system for the basement is a unique feature of the Airtech 107 and will transform the dampest, mustiest basement into a dry, comfortable living area or

storage space. The recirculation system takes fresh, dry air from the upper levels of the house and recirculates it to the basement before exhausting it to the outside.

For this type of installation, it is necessary for the forced-air blower to run in synchronization with the Airtech 107 (see section 6.2 for installation details).

Homes with two stories or more will require at least one exhaust vent at the highest level of the house.

In the basement it is recommended to have at least one exhaust vent close to the floor as the humidity in a basement tends to concentrate near the floor.

## 5.0 Pre-Installation Survey

Before you arrive with your full complement of tools and parts ready to start cutting holes and laying ductwork, it is important to do a pre-installation survey of the residence to determine the appropriate installation scenario and plan the most effective and efficient layout.

### 5.1 Locate the Unit

- In new construction, the unit should typically be located in the dedicated mechanical or utility room. These rooms are ideally located in the basement, away from living and sleeping areas and close to available power sources (and existing ductwork in the case of installation scenario 4.2)
- If a dedicated mechanical or utility room is not present, which is likely the case in most retrofit situations, you should take the following into consideration when determining the best location to hang the Airtech 107:
  - Location must allow for easy access to all duct connections, the unit's interior filters, and the control panel.
  - It is best to hang the unit close to an exterior wall to keep exterior supply and ventilation lines as short as possible.
  - Unit should be hung away from any hot surfaces or potential fire hazards
  - Location must allow for a power source (standard outlet)
  - Consider proximity to existing forced-air blower in the case of installation scenario 4.2

### 5.2 Plan the Ductwork

You will likely begin developing a plan for your ductwork when you are considering the best location to hang the Airtech 107. When developing this plan, allow for the following considerations:

- Duct size - We recommend 8" flex duct connecting to and from the unit, tapered to 6" ductwork throughout the house for optimal flow and noise reduction. This is a recommendation only. Please consult the table below for further details on selecting duct sizes.

Duct Size	Flex Duct				Smooth Duct			
Fan Rating: CFM @ 0.25 in. wg (L/s @62.5 Pa)	50 (25)	80 (40)	100 (50)	125 (65)	50 (25)	80 (40)	100 (50)	125 (65)
Diameter in. (mm)	Maximum Duct Length ft. (m)							
3 (75)	X	X	X	X	5 (2)	X	X	X
4 (100)	70 (27)	3 (1)	X	X	105 (35)	35 (12)	5 (2)	X
5 (125)	NL	70 (27)	35 (12)	20 (7)	NL	135 (45)	85 (28)	55 (18)
6 (150)	NL	NL	125 (42)	95 (32)	NL	NL	NL	145 (48)
7 (175) and above	NL	NL	NL	NL	NL	NL	NL	NL

This table assumes no elbows. Deduct 15 feet (5m) of allowable length for each elbow.

NL = No Limit

X = Not Allowed

\*Please refer to section 2.0 chapter 2.3 Product Data for CFM ratings for the Airtech 107

## 6 | Installation Instructions

- Do not install or tie-in to ducts smaller than 4" in diameter as air flow decreases considerably.
- Insulated flex ducts must be used for all exterior connections, and are recommended for use in all bedroom connections for additional noise reduction.
- Keep it simple. Locate exhaust and supply vents in practical but inconspicuous places. Plan for a minimum of bends and joints. Keep the length of insulated flex ducts to a minimum.
- Exhaust vents should be located in the kitchen, all bathrooms and the basement. Supply vents should be located in the living room, all bedrooms and the basement. Be sure to include one exhaust register on the highest lived-in level of the house in the case of residences with two or more stories.
- Some jurisdictions may require a grease filter for kitchen exhaust inlet to ERV/HRV. Keep kitchen exhaust inlet 40 " from cooking surface. Please follow local building codes to conform with requirements for kitchen exhaust inlets.
- Do not use wall cavities as ducts

### 6.0 Installation Instructions

#### Warning

This manual details the recommended installation method only. Any structural alterations necessary for installation must comply with local building, fire, health, and safety code requirements.

Before beginning the installation, inspect the unit and the contents of the box for:

- Damage - Inspect both the exterior and interior of the unit for any shipping damage to the door, latches, hinges, dampers, duct collars, filters, motor assembly, etc.
- Accuracy - Refer to the attached parts list to ensure no parts are missing.

If there is any damage or any parts are missing, please contact your local distributor immediately. All claims must be made within 30 days of delivery.

#### 6.1 Installing Exterior Hoods & Vents

Now that you know where your unit will be located and how your ductwork will be laid out, you can begin the actual installation. Start by choosing an appropriate location for installing the exterior hoods and vents:

- Maximize your distance between the fresh air supply vent and the stale air exhaust vent to prevent cross-contamination. We recommend a minimum distance of 6 feet (1.8 m) between vents.\*
- Both exhaust and supply vents must be installed a minimum distance of 18 inches (45.7 cm) from the ground.\*
- The exhaust vent should not dump stale air into an enclosed space.
- Make sure the supply vent is at least 6 feet (1.8 m) away from any of the following:
  - Dryer exhaust, central vacuum vent, furnace vent, etc.
  - Gas meter exhaust, gas barbecue grill
  - Garbage bins and other sources of possible contamination
  - Any exhaust from a combustion source, etc.

Once you've established an appropriate location for your exterior vents and hoods, drill the necessary holes and proceed with the installation.

#### Additional instructions:

- The exhaust and supply vents should be screened against insects and vermin with screening material no less than ¼" or as per local building codes.

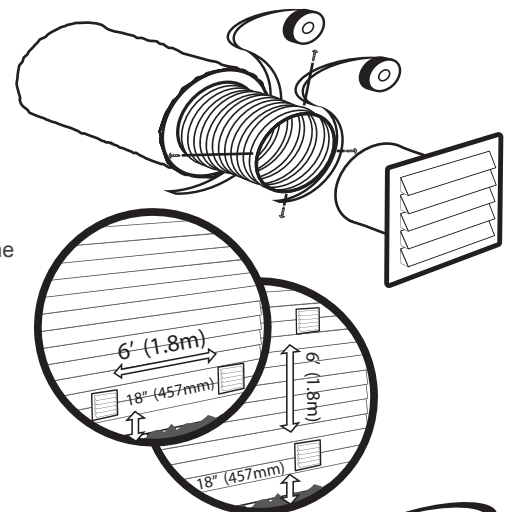

- OPTIONAL: Vents can be covered with suitable hoods to prevent against the entry of rain or snow; however, this may reduce air flow volume to and from the unit.
- If you are installing vents and corresponding insulated flex ducts through an abrasive surface such as concrete, use a solid metal thimble to avoid tearing of the flexible material
- Insulate all exterior openings with appropriate spray foam insulation once flex ducts are securely in place.
- Do not secure any ductwork to the unit itself until section 6.4 Connecting Ducts to the Unit.

## 6.2 Installing Interior Ductwork & Vents

### Warning

Never install a stale air exhaust vent in a room where a combustion device operates, such as a gas or oil furnace, a gas water heater, or a fireplace.

### 6.2.1 Fully Ducted System (See Illustration Section 4.1)

#### Exhaust System

- Begin by installing vents in areas where contaminants and excessive humidity are produced – kitchen, bathrooms, basement, laundry rooms, etc.
- If the residence has two or more stories, ensure at least one exhaust vent is installed in the highest level of the house.
- Typically, exhaust vents should be installed on an interior wall, 6 to 12 inches from the ceiling.

#### Steps:

- Measure vent and register, wall grill, or diffuser, and cut hole accordingly.
- Secure vent flanges to wallboard or floorboard using sheet metal screws.
- Attach flex duct to vent collar through the spiral flex wire using sheet metal screws.
- If using insulated flex duct, be sure to pull the insulation back to expose the actual flex duct before attaching. Do not screw through insulation.
- Secure and seal the connection appropriately.
- Insert the register, wall grill, or diffuser into the top side of the opening.

#### Supply System:

- Once your exhaust vents and ductwork are installed, begin installing fresh air supply vents in the bedrooms and other living areas.
- Typically, supply vents should be installed in the ceiling or on an interior wall as close to the ceiling as possible, with air flow directed towards the ceiling.
- In retrofit situations, limited access to the ceiling and/or interior walls may make it necessary to install a supply vent in the floor. If this is the case, direct the air flow up the wall.

#### Steps:

- Repeat connection steps outlined above in Exhaust System installation

#### Recirculation System:

- The basement recirculation system will be the final series of vents and ductwork installed. Should your basement contain multiple rooms, recirculation supply vents can be installed in the largest rooms, or in each separate room if so desired. In all cases, there should be a minimum of 10 feet between exhaust and recirculation supply vents.
- The recirculation exhaust vent should be ducted to the main level of the house, either with a separate duct or via the main exhaust system.

## 8 | Installation Instructions

- Recirculation vents should be installed in the ceiling or on an interior wall as close to the ceiling as possible, with air flow directed towards the ceiling.

### Steps:

- Repeat connection steps outlined above in Exhaust System installation

## 6.2.2 Pre-existing Ductwork

### 6.2.2.1 New Exhaust and Recirculation

(See illustration Section 4.2)

#### Exhaust System:

- Refer to point 6.2.1 of chapter 6.2 – Fully Ducted System. Considerations and installation are identical.

#### Supply System:

### Warning

When performing duct connection to an existing forced-air system, installation must be done in accordance with all applicable codes and standards. Please refer to your local building code.

- In the case of a pre-existing forced-air heating or cooling system, the Airtech 107 will use the existing ductwork and supply vents to supply fresh air to the bedrooms and living areas. Ensure all supply vents are at least 10 feet away from all exhaust vents.
- Since forced-air configurations vary between suppliers and builders, it is recommended that there be at least one supply vent on each main living level of the house, as well as in the basement.
- Because forced-air blowers operate at much higher CFM rates than the Airtech 107, a metal T-duct with a backdraft vent must be installed at the primary connection point to prevent excessive air flow through the Airtech 107 when the blower is engaged.

### Steps:

- Make sure blower is turned off.
- Measure and cut hole for metal T-duct in the return plenum of the forced-air handler.
- Secure T-duct to return plenum with sheet metal screws. Seal appropriately.
- Attach backdraft vent to one side of T-duct.
- Attach flex duct from the supply vent of the Airtech 107 to the other side of the T-duct. Secure through spiral flex wire with sheet metal screws. Seal appropriately.

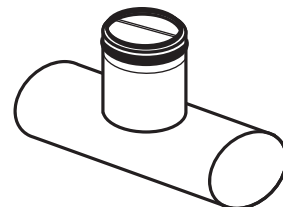

#### Recirculation System:

Refer to point 6.2.1 of chapter 6.2 – Fully Ducted System. Considerations and installation are identical.

### 6.2.2.2 New Recirculation Only

(See illustration Section 4.2)

#### Exhaust System:

- This scenario will use the forced-air heating or cooling system and ductwork to exhaust contaminated air from the house through the Airtech 107.
- Since forced-air configurations vary between suppliers and builders, it is recommended that there be at least one exhaust vent in the basement and on each main living level of the house.
- Because forced-air blowers operate at much higher CFM rates than the Airtech 107, a metal T-duct with a backdraft vent must be installed at the primary connection point to prevent excessive air flow through the Airtech 107 when the blower is engaged.

**Steps:**

- Make sure blower is turned off
- Measure and cut hole for metal T-duct in the return plenum of the forced-air handler
- Secure T-duct to return plenum with sheet metal screws. Seal appropriately.
- Attach backdraft vent to one side of T-duct
- Attach flex duct from the supply vent of the Airtech 107 to the other side of the T-duct. Secure through spiral flex wire with sheet metal screws, seal appropriately.

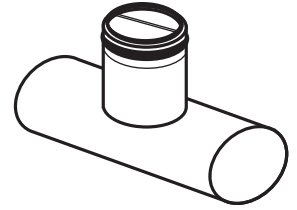
**Supply System:**

Refer to sub-point 6.2.2.1 of point 6.2.2 – New Exhaust and Recirculation. Considerations and installation are identical.

**Recirculation System:**

Refer to point 6.2.1 of chapter 6.2 – Fully Ducted System. Considerations and installation are identical.

**Caution**

If doing a New Recirculation Only installation, ensure the forced-air blower operation is synchronized with the unit operation

**6.3 Mounting the Unit**

With all of your vents and ductwork now successfully installed, it is time to mount the Airtech 107 in the location you chose in section 5.0:

- Use the 4 chains provided and unit-mounted hooks to suspend the unit directly from the floor joists overhead.
- Make sure the unit is level.
- Make sure the unit's power cord can reach the nearest electrical outlet, or make provisions for a new outlet to be installed near the unit.

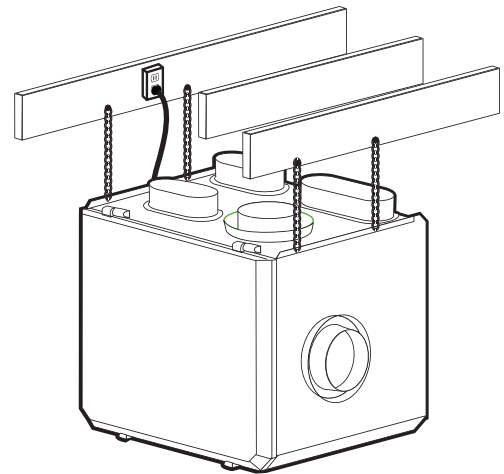
**6.4 Connecting Ducts to Unit**

Your unit is now firmly in place and your ductwork is laid and fully installed. It is now time for the final step – connecting your carefully planned ductwork to the Airtech 107. In most installations you will be using a combination of 8" insulated and non-insulated flexible ducts for these connections. If you have used 6" ductwork throughout the house, you may want to taper up to 8" ducts when connecting to the Airtech for added noise reduction, though it is not necessary.

**Flex Ducts:**

- Typically coming from interior supply, exhaust and recirculation lines
- Before connections are made to the unit itself, a T-duct must be attached to the main exhaust line, allowing the main exhaust line to be connected to both the exhaust and recirculation ports of the Airtech 107.
- Slide exhaust lines over inner collar (6") or outer collar (8") of double-collared exhaust and recirculation ports.
- Secure with sheet metal screws. Seal appropriately.
- Repeat this procedure for the fresh air supply lines, making sure to connect the basement recirculation line and the upper-level(s) supply line to their corresponding port.

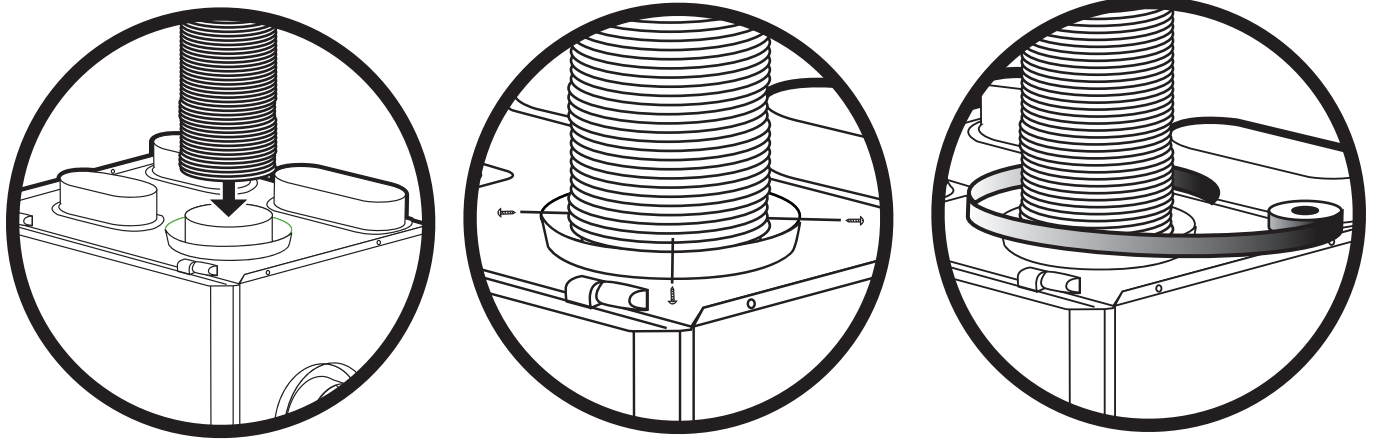

### Insulated Flex Ducts:

- Typically coming from exterior supply and exhaust lines, except in instances where additional noise reduction is required on interior lines.
- Pull back the insulation to expose the flex duct underneath.
- Slide flex duct over inner collar (6") or outer collar (8") of double-collared exhaust port.
- Secure with sheet metal screws. Seal appropriately.
- Carefully pull the insulation back over the joint and tuck it between the inner and outer collar (6") or over top of the flex duct (8").
- Pull the vapor barrier back over the insulation and over the outer collar of the double-collared exhaust port (6") or over top of the entire assembly (8").
- Seal joint appropriately. Try to avoid compressing the insulation while sealing, as compressed insulation loses its R value and may lead to unwanted condensation.

### Caution

Do not tear the vapor barrier on the insulated ducts during installation. A torn vapor barrier may create condensation within the duct.

### Insulated Flex Ducts: Visual Steps

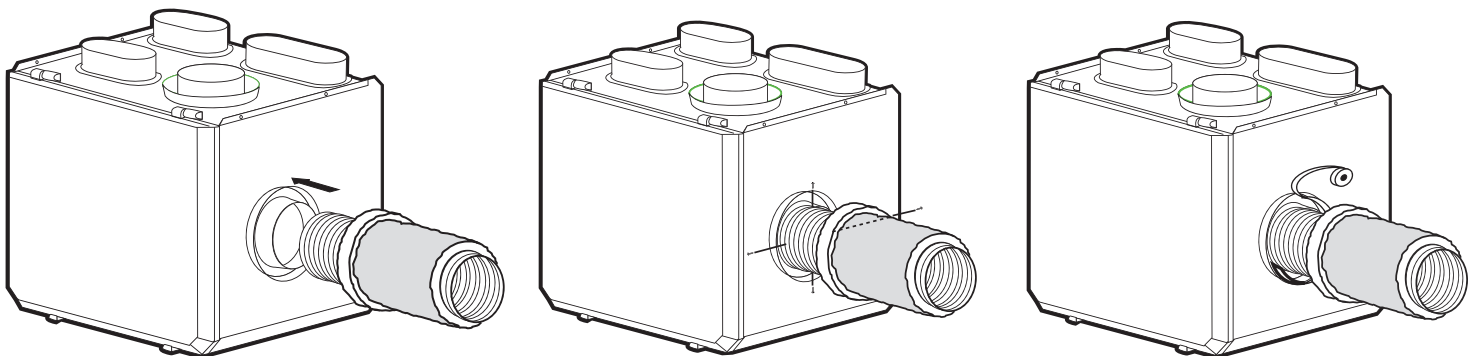

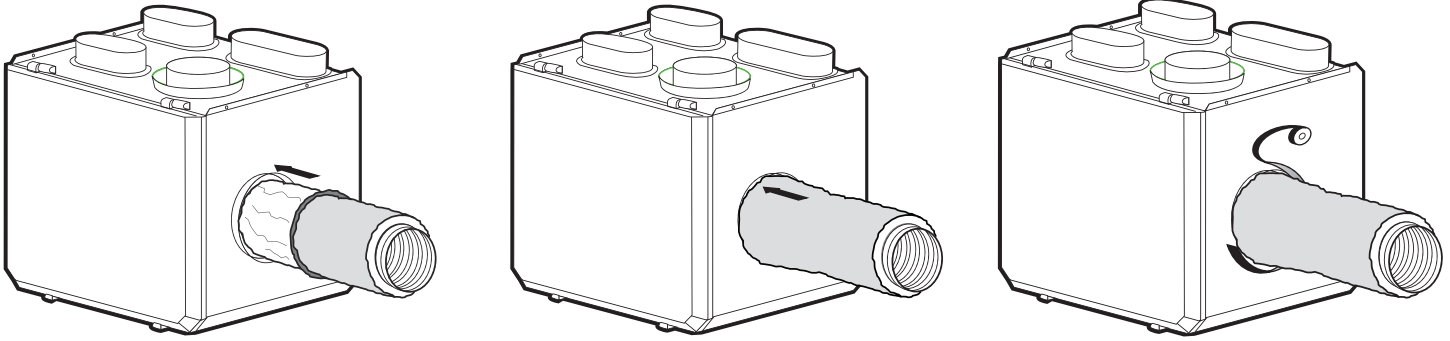

## 7.0 Electrical Controls

To power-up the Airtech 107 simply plug its power cord into any available 115 VAC outlet. If the main service door is closed, the unit will start running immediately. A safety disconnect switch cuts all power to the unit when the main service door is opened or removed.

### Unit-Mounted Controls:

For optimal performance, position the manual rocker switch located on the exterior of the unit to low, medium or high according to house size:



Unplug unit before installing controls

#### For Fully Ducted System:

- Low for houses up to 2500 square feet
- Medium for houses up to 3500 square feet
- High for houses over 3500 square feet

#### For Existing Forced-Air System:

- Low for houses up to 3500 square feet
- Medium for houses up to 5000 square feet
- High for houses over 5000 square feet

### Wall-Mounted Controls:

One dehumidistat is included with the Airtech 107 to act as the unit’s main control for the entire household. Optional controls including additional dehumidistats and remote timers can also be installed to allow control of the unit from various locations throughout the residence.

#### Installing the Primary Dehumidistat:

- Choose a central and accessible location on an interior wall not next to windows, ducts, or heat sources. A central hallway is recommended.
- Cut holes in wall to accommodate wires, anchors and screws (anchors and screws provided).
- Remove front cover of dehumidistat. Pass wires through hole near terminal block. Secure dehumidistat to wall through appropriate holes with provided anchors and screws.
- Attach wires (sold separately) to appropriate locations. Standard communication wire is recommended.
- Pull wire back through walls and/or ceiling to the Airtech 107.
- Attach wires to corresponding locations on the unit.

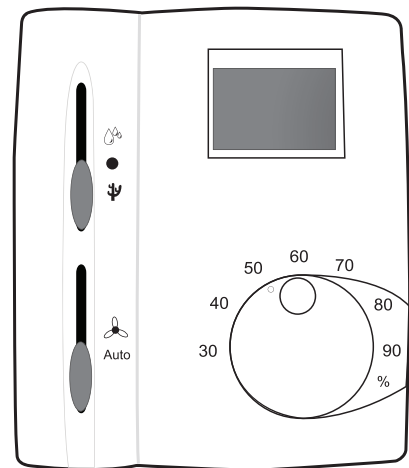

Please refer to additional instructions included with your primary dehumidistat for further clarification.

## 12 | How to Operate the Controls

### Installing a Remote Timer:

Optional remote timers can be installed in each of the house's bathrooms if needed. The process for doing so is the same as installing the primary dehumidistat. Be sure to connect electrical wires to the dedicated Optional Controls portion of the connection panel on the Airtech 107.

### Corresponding connections for wall-mounted controls and Airtech 107

#### 20-minute timer

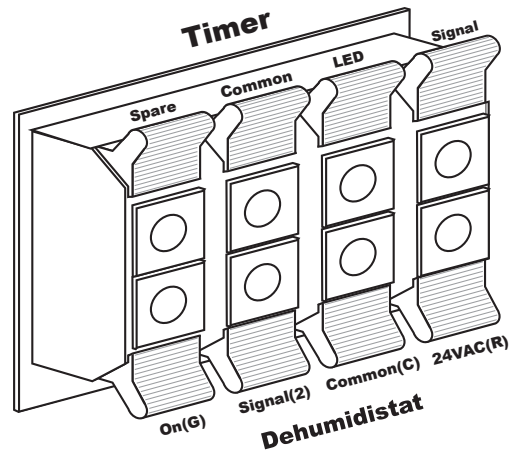
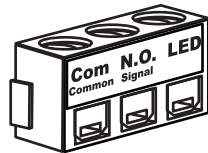

#### Dehumidistat



## 8.0 How to Operate the Controls

### 8.1 Primary Dehumidistat

#### Top Switch -

Set the top switch to all the time in order to regulate your home's humidity. The other top switch settings shown and are not used on the Airtech 107 and can therefore be ignored.

#### Bottom Switch -

Set the bottom switch to "automatic" when you want the dehumidistat to engage the Airtech 107 automatically when it detects excess humidity.

Set the bottom switch to when you want the Airtech 107 to engage immediately and remain engaged all the time.

#### Rotary Dial -

Turn the rotary dial clockwise for drier air, for homes with more humidity; counter-clockwise for less humidity reduction in homes with less humidity.

If your home is feeling humid and the Airtech 107 is not engaged, simply turn the rotary dial clockwise for increased humidity reduction.

The following humidity settings are recommendations based on season:

Summer = 60%.

Spring and Fall = 45%

Winter = 30% (where temperatures are below -10°C or 14°F.)

### 8.2 20-Minute Timer

The 20-minute timer is engaged and disengaged at the press of a button. When the button is pressed once, the Airtech 107 fan is engaged at the "high" setting for a duration of 20 minutes. The Airtech 107 can be disengaged immediately by pressing the button a second time.

The 20-minute timer is typically used after showers or during other contaminant and humidity-producing activities in your home's bathrooms.

## 9.0 Verifying the Installation

Once everything is in place and properly connected, use the following procedures to test your unit and its controls for proper and consistent performance.

### 9.1 Unit-mounted Controls

This procedure allows the installer to verify that all modes of operation are fully functional. During the verification of the manual rocker switch ensure that the primary dehumidistat is set to “fan” and all optional controls are inactive.

Switch Position	Expected Results
Low	Low fan speed
Medium	Medium fan speed
High	High fan Speed



### 9.2 Primary Dehumidistat

Before testing your primary dehumidistat, set the unit-mounted rocker switch according the size of the house you are in (refer to table, section 7.0). Also, ensure all optional controls are inactive.

#### Procedure:

- Set top switch to 
- Set bottom switch to “automatic”

#### Expected Results:

- If  symbol on LCD is flashing, unit should be operating
- If  symbol on LCD is static, unit should be on standby

*\*Note: Please allow for a two minute delay (approx.) when switching between functions*

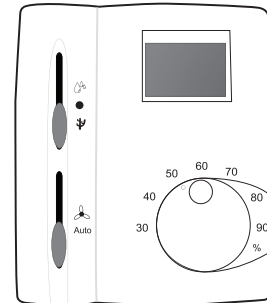

### 9.3 Optional Controls

#### Additional Dehumidistats:

Additional dehumidistats will operate in parallel with the primary dehumidistat and should perform likewise.

#### 20-Minute Remote Timer:

Activate the push button on each remote timer. The following should occur:

- Fan speed should increase to HIGH for 20 minutes
- Indicator light on the timer goes ON
- When button is pressed again, unit should turn off and the indicator light should go out.



## 10.0 Scheduled Maintenance

### Warning

Risk of electrical shock. Before performing any maintenance or servicing, always disconnect the unit from its power source.

If you will not be the primary user of this unit, review with the primary user the following steps required for regular maintenance of his/her new Airtech 107 system:

## 14 | Scheduled Maintenance / Certifications and References

### Twice per year or as needed:

- Clean the filters – Open the main service door and remove all three filters. Wash or replace filters as necessary.
- Clean the cabinet interior and main service door.

### Once per year or as needed:

- Clean the main exchange cores – Open the main service door and remove the cores. Vacuum or wash as necessary, then replace. **DO NOT USE A PRESSURE WASHER!**

Replacement Filters	
MH 100 138	Optional Electronic Air Cleaner
MH 100 524	Optional Electronic Air Cleaner Media
MP 100 139	Incoming Filter
MP 100 140	Lower Left Filter
MP 100 141	Lower Right Filter

## Caution

Do not run the unit while filters are removed due to the risk of contaminants entering the home and eventually clogging the main exchange cores.

## 11.0 Certifications / References

**Exhaust Air Transfer Ratio:** 0.008

**Airflow Range for Multispeed Units:**

High Speed: 57 L/s Medium Speed: 48 L/s Low Speed: 38 L/s

### Ventilation Performance

External Static Pressure		Net Supply Air Flow		Gross Air Flow				Power
				Supply		Exhaust		
Pa	in. W.C.	L/s	cfm	L/s	cfm	L/s	cfm	Watts
25	0.1	57	122	58	123	56	120	86
50	0.2	52	110	52	111	49	105	90
75	0.3	46	99	47	100	44	93	93
100	0.4	41	87	41	87	36	76	97
125	0.5	34	73	34	73	31	65	100
150	0.6	26	54	26	55	21	44	103

Note: Fan Curve Performance on High Speed

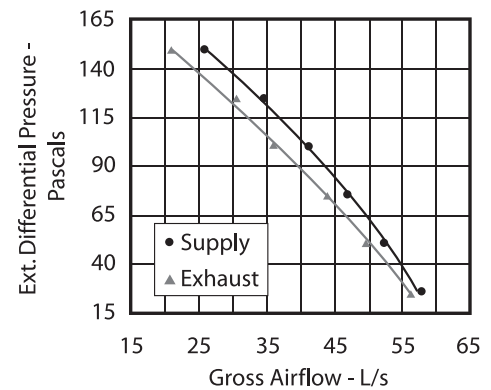

### Energy Performance

		Supply Temperature		Net Airflow		Supply / Exhaust Flow Ratio	Average Power (Watts)	Sensible Recovery Efficiency	Apparent Sensible Effectiveness	Net Moisture Transfere
		°C	°F	L/s	cfm					
Heating	i	0	32	31	66	1.02	52	71	80	0.60
	ii	0	32	41	88	1.03	68	67	76	0.55
	iii	0	32	48	103	1.02	90	65	73	0.53
	iv									
	v									
Cooling	vi	35	95	30	64	1.00	52	55**	70	0.55

\*\* Indicates Total Recovery Efficiency not Sensible Recovery Efficiency  
250 Pascals = 1" of Water : 0.47 L/s = 1 cfm



## 12.0 Troubleshooting

### 12.1 Airtech 107

Switch Position	Expected Results	Possible Solutions
Nothing is working	<ul style="list-style-type: none"> <li>Unit is not plugged in, or plugged in improperly.</li> <li>Circuit breaker in main electrical panel is tripped.</li> <li>Main service door is open or improperly secured</li> </ul>	<ul style="list-style-type: none"> <li>Plug the unit into the wall outlet, or remove and re-plug.</li> <li>Reset the breaker. If problem persists, verify with a multimeter that the outlet in question is receiving power.</li> <li>* Verify that the main service door is completely closed and latched.</li> </ul>
<b>Dehumidistat</b>		
<ul style="list-style-type: none"> <li>No display.</li> <li>Blinking or intermittent display</li> </ul>	<ul style="list-style-type: none"> <li>Improperly wired to unit.</li> <li>Dehumidistat is defective</li> </ul>	<ul style="list-style-type: none"> <li>Unplug unit. Verify wires from dehumidistat are connected properly. Remove front cover of dehumidistat and ensure wires are connected properly to terminal block. Check length of wire for breaks or damage</li> </ul>
<ul style="list-style-type: none"> <li>Controls fail to engage the unit when demand is created</li> </ul>	<ul style="list-style-type: none"> <li>Controls are not set properly.</li> <li>2 minutes have not yet passed between function changes</li> </ul>	<ul style="list-style-type: none"> <li>Ensure top switch is set to dehumidify </li> <li>Ensure bottom switch is set to automatic</li> <li>Ensure you allow 2 minutes for unit to reset after switches have been moved</li> </ul>
<ul style="list-style-type: none"> <li>Controls fail to disengage the unit when there is no demand</li> </ul>	<ul style="list-style-type: none"> <li>Controls are not set properly.</li> <li>2 minutes have not yet passed between function changes</li> </ul>	<ul style="list-style-type: none"> <li>Ensure bottom switch is set to automatic.</li> <li>Ensure you allow 2 minutes for unit to reset after switches have been moved</li> </ul>
<b>Unit Controls</b>		
<ul style="list-style-type: none"> <li>Fan speed switch not working</li> </ul>	<ul style="list-style-type: none"> <li>Unit is not in demand</li> <li>Switch is defective</li> </ul>	<ul style="list-style-type: none"> <li>Unit must be in demand to alter fan speed. The fan speed will change the next time the unit detects excess humidity</li> </ul>
<b>20 Minute Timer</b>		
<ul style="list-style-type: none"> <li>No light – light not working</li> </ul>	<ul style="list-style-type: none"> <li>Timer is improperly wired to unit.</li> <li>Timer or light is defective</li> </ul>	<ul style="list-style-type: none"> <li>Unplug unit and inspect timer connections. Verify they are correctly installed. Remove timer from wall and check wiring for correct installation. Inspect length of wire for breaks or damage</li> </ul>

12.2 Home Ventilation

Problem	Possible Causes	Possible Solutions
Condensation on windows	<ul style="list-style-type: none"> <li>• Controls are set improperly</li> <li>• Air around windows is not properly circulated</li> <li>• Thermostat of your home heating system is set too low</li> </ul>	<ul style="list-style-type: none"> <li>• Refer to section 8.0 How to use the Controls in order to set the unit and dehumidistat controls properly</li> <li>• Leave your curtains open at least half way to allow proper air circulation around the windows</li> <li>• Do not set your home heating thermostat below 18°C (65°F)</li> </ul>
Indoor air is too dry	<ul style="list-style-type: none"> <li>• Controls are set improperly</li> </ul>	<ul style="list-style-type: none"> <li>• Refer to section 8.0 How to use the Controls in order to set the unit and dehumidistat controls properly</li> </ul>
Air coming from air supply grill is too cold	<ul style="list-style-type: none"> <li>• Controls are set improperly</li> <li>• Outside vents/hoods are blocked</li> <li>• Filters and cores of unit have become blocked or excessively dirty</li> </ul>	<ul style="list-style-type: none"> <li>• Refer to section 8.0 How to use the Controls in order to set the unit and dehumidistat controls properly</li> <li>• Inspect and clean outside vents/ hoods if necessary</li> <li>• Inspect and clean filters and cores of unit if necessary</li> </ul>
Not enough fresh air	<ul style="list-style-type: none"> <li>• Controls are set improperly</li> <li>• Motor is malfunctioning</li> <li>• Outside vents/hoods are blocked</li> <li>• Filters and cores of unit have become blocked or excessively dirty</li> </ul>	<ul style="list-style-type: none"> <li>• Refer to section 8.0 How to use the Controls in order to set the unit and dehumidistat controls properly</li> <li>• Check motor operation and call your installer if any motors are not working</li> <li>• Inspect and clean outside vents/ hoods if necessary</li> <li>• Inspect and clean filters and cores of unit if necessary</li> </ul>

If your problem is still not resolved after executing all of these troubleshooting techniques, please call Airtech 107 Customer Service at **1-800-416-9111**

## 13.0 Options

The following optional controls and accessories are available for your Airtech 107 in addition to those supplied with the unit upon delivery. Please talk to your local distributor if you wish to include any or all of these options with your installation.

### 13.1 20-Minute Timer

- Lighted push button
- Press once to activate. The Airtech 107 will operate on "high" for 20 minutes and the indicator light will turn on
- Press once more to deactivate at any time during the 20 minute cycle
- Replacement Part # AS 100 523



### 13.2 Fresh Outside Air Filter Upgrade

- Electronic Air Cleaner
- Effortlessly traps airborne particles less than 1 micron
- Provides same performance as a HEPA filter
- 24 volts AC/DC
- 5 year warranty Air Cleaner
- Filter change is recommended every 3 to 6 months
- \* Replacement Part # MH 100 138
- Replacement Media Part # MH 100 524

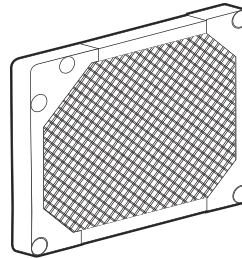

### 13.3 UV Germicidal Light

- Can be used for the fresh air supply to the upper levels and/or the recirculation air to the basement
- Provides additional sterilization of exterior air entering the house
- Replacement Part # MH 100 522

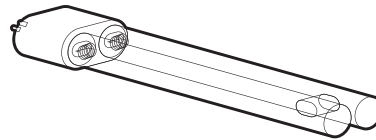

### 13.4 230 VAC option

The Airtech 107 is already compatible with 230 VAC 50 or 60 Hz. To convert the 107 from 120 VAC to 230 VAC follow the steps below

1. Unscrew side screws to release the back plate.

2. Remove the back plate.

3. Find the Power supply in the lower left hand of the right hand compartment.

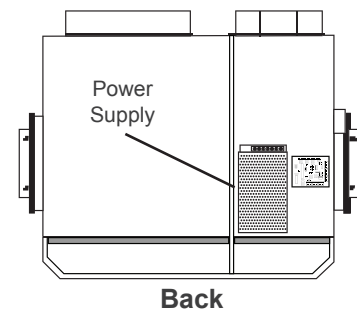
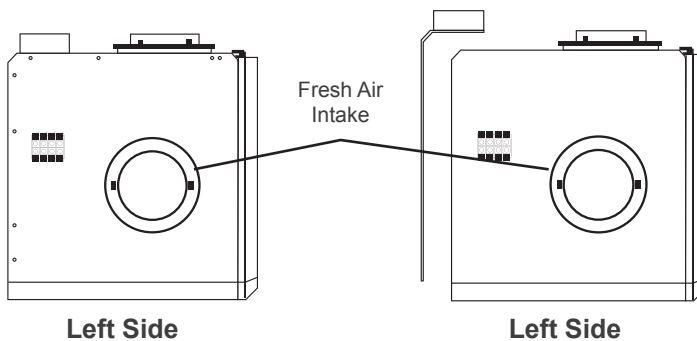

4. Locate the voltage switch on the right hand side of the power supply.

5. Set the Voltage switch to the desired voltage.

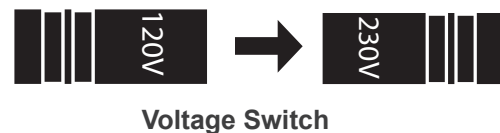
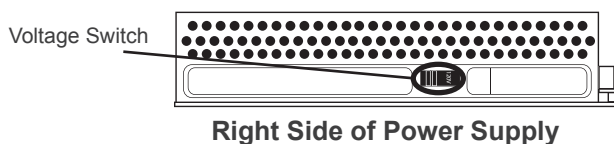

# 14.0 Electrical Diagram

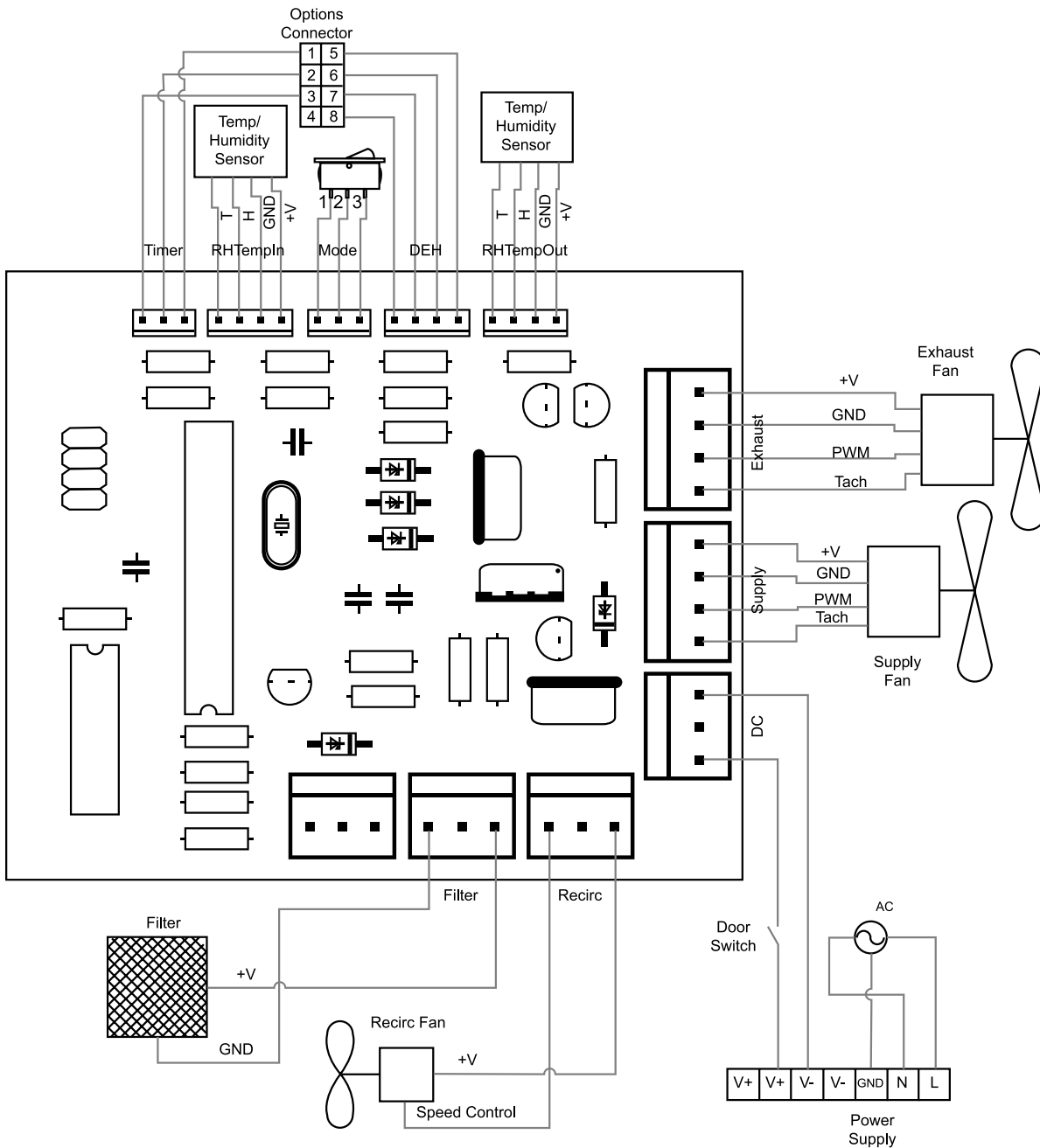

# 15.0 Personal Information

Serial Number: \_\_\_\_\_

Purchase Date: \_\_\_\_\_

Date of Installation: \_\_\_\_\_

Dealer Name: \_\_\_\_\_

Dealer Phone Number: \_\_\_\_\_



## Warranty Mail-In

Mail in warranty information or register online (<http://www.airtech107.com/service.php>)

First Name: \_\_\_\_\_

Purchase Date: \_\_\_\_\_

Last Name: \_\_\_\_\_

Phone Number: \_\_\_\_\_

Serial Number: \_\_\_\_\_

Dealer: \_\_\_\_\_

### Address:

Street: \_\_\_\_\_

City: \_\_\_\_\_

State/Province: \_\_\_\_\_

Zip/Postal Code: \_\_\_\_\_

Country: \_\_\_\_\_





